

AD ARCH FENDERS

Maritime International's AD Arch fender is a V type fender that has been optimized for increased energy absorption compared to traditional arch fenders on the market. They are particularly useful for vessels with high allowable hull pressures and for locations where mounting space is limited. A variety of sizes and lengths are offered. Additionally these fenders can be supplied with bolted or bonded UHMW facings.



AD ARCH RUBBER FENDERS

AD GEOMETRY

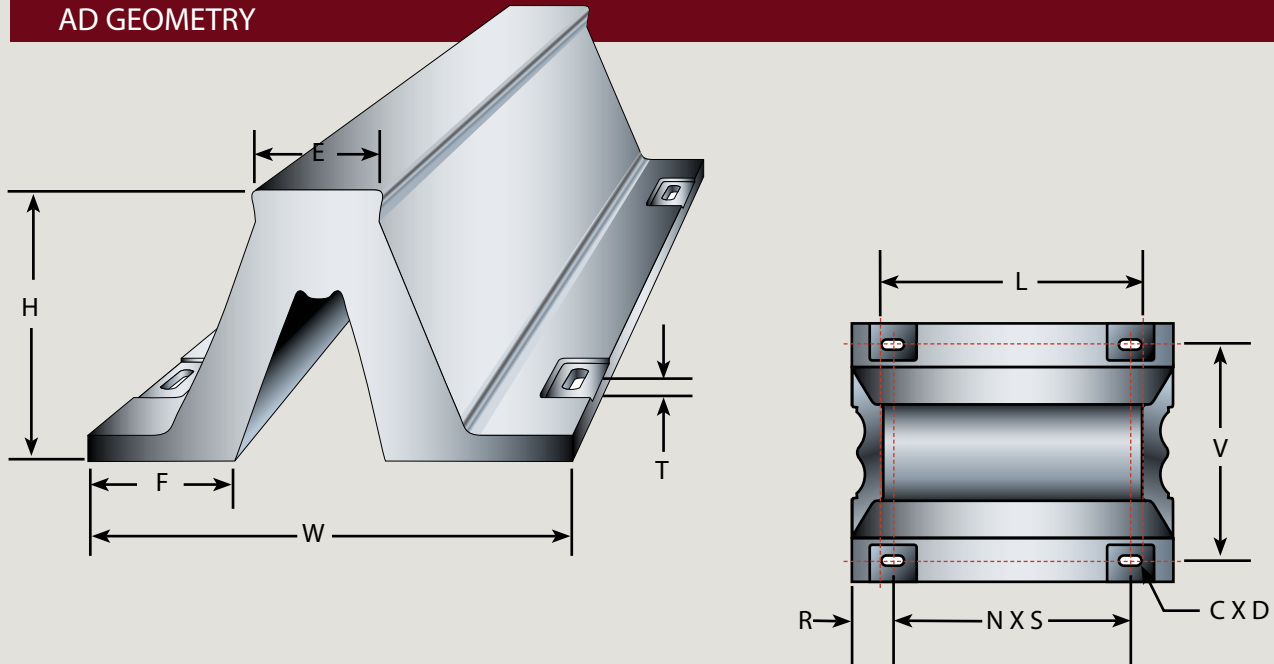

AD DIMENSIONS

Model	H		W		V		E		F		T		C X D		Bolt Size	
	mm	in	mm	in	mm	in	mm	in	mm	in	mm	in	mm	in	mm	in
AD 250	250	9.84	500	19.7	410	16.1	164	6.46	160	6.30	20.5	0.81	32 X 64	1.26 X 2.52	M27	1
AD 300	300	11.8	600	23.6	490	19.3	225	8.86	195	7.68	24	0.94	35 X 70	1.38 X 2.76	M30	1-1/8
AD 400	400	15.7	800	31.5	670	26.4	300	11.8	260	10.2	30	1.18	41 X 82	1.61 X 3.23	M36	1-3/8
AD 500	500	19.7	1000	39.4	840	33.1	375	14.8	325	12.8	33	1.30	47 X 94	1.85 X 3.70	M42	1-1/2
AD 600	600	23.6	1200	47.2	1010	39.8	450	17.7	390	15.4	36	1.42	50 X 100	1.97 X 3.94	M48	1-3/4
AD 800	800	31.5	1600	63.0	1340	52.8	600	23.6	520	20.5	45	1.77	68 X 136	2.68 X 5.35	M64	2-1/2
AD 1000	1000	39.4	2000	78.7	1680	66.1	750	29.5	650	25.6	60	2.36	68 X 136	2.68 X 5.35	M64	2-1/2

all dimensions are in inches

Model	L											
	3.28ft		4.92ft		6.56ft		8.2ft		9.84ft		11.48ft	
	R	N X S	R	N X S	R	N X S	R	N X S	R	N X S	R	N X S
AD 250	5.12	1 X 34.1	5.22	2 X 26.8	5.22	3 X 24.4	5.02	3 X 31.1	5.22	4 X 28.6	5.12	5 X 26.5
AD 300	5.51	1 X 34.3	5.51	2 X 27.0	5.41	3 X 24.6	5.51	3 X 31.1	5.71	4 X 28.6	5.51	5 X 26.5
AD 400	5.91	1 X 35.4	5.91	2 X 27.6	5.81	3 X 25.0	5.91	3 X 31.5	5.91	4 X 28.6	5.91	5 X 26.8
AD 500	6.30	1 X 36.6	6.30	2 X 28.2	6.20	3 X 25.4	6.30	3 X 31.9	6.50	4 X 28.7	6.30	5 X 27.0
AD 600	6.69	1 X 37.8	6.69	2 X 28.7	6.59	3 X 25.8	6.69	3 X 32.3	6.69	4 X 29.1	6.69	5 X 27.2
AD 800	7.09	1 X 40.9	7.09	2 X 30.3	7.09	3 X 26.8	7.19	3 X 33.3	7.09	4 X 29.9	-	-
AD 1000	7.87	1 X 43.3	7.87	2 X 31.5	7.87	3 X 27.6	-	-	-	-	-	-

all dimensions are in millimeters

Model	L											
	1m		1.5m		2m		2.5m		3m		3.5m	
	R	N X S	R	N X S	R	N X S	R	N X S	R	N X S	R	N X S
AD 250	130	1 x 865	133	2 x 680	133	3 x 620	128	3 x 790	133	4 x 715	130	5 x 673
AD 300	140	1 x 870	140	2 x 685	138	3 x 625	140	3 x 790	145	4 x 715	140	5 x 674
AD 400	150	1 x 900	150	2 x 700	148	3 x 635	150	3 x 800	150	4 x 725	150	5 x 680
AD 500	160	1 x 930	160	2 x 715	158	3 x 645	160	3 x 810	165	4 x 730	160	5 x 686
AD 600	170	1 x 960	170	2 x 730	168	3 x 655	170	3 x 820	170	4 x 740	170	5 x 692
AD 800	180	1 x 1040	180	2 x 770	180	3 x 680	183	3 x 845	180	4 x 760	-	-
AD 1000	200	1 x 1100	200	2 x 800	200	3 x 700	-	-	-	-	-	-

Other sizes available. Dimensions are subject to change. Verify current dimensions with Maritime when ordering any fender.

AD GENERALIZED PERFORMANCE CURVE

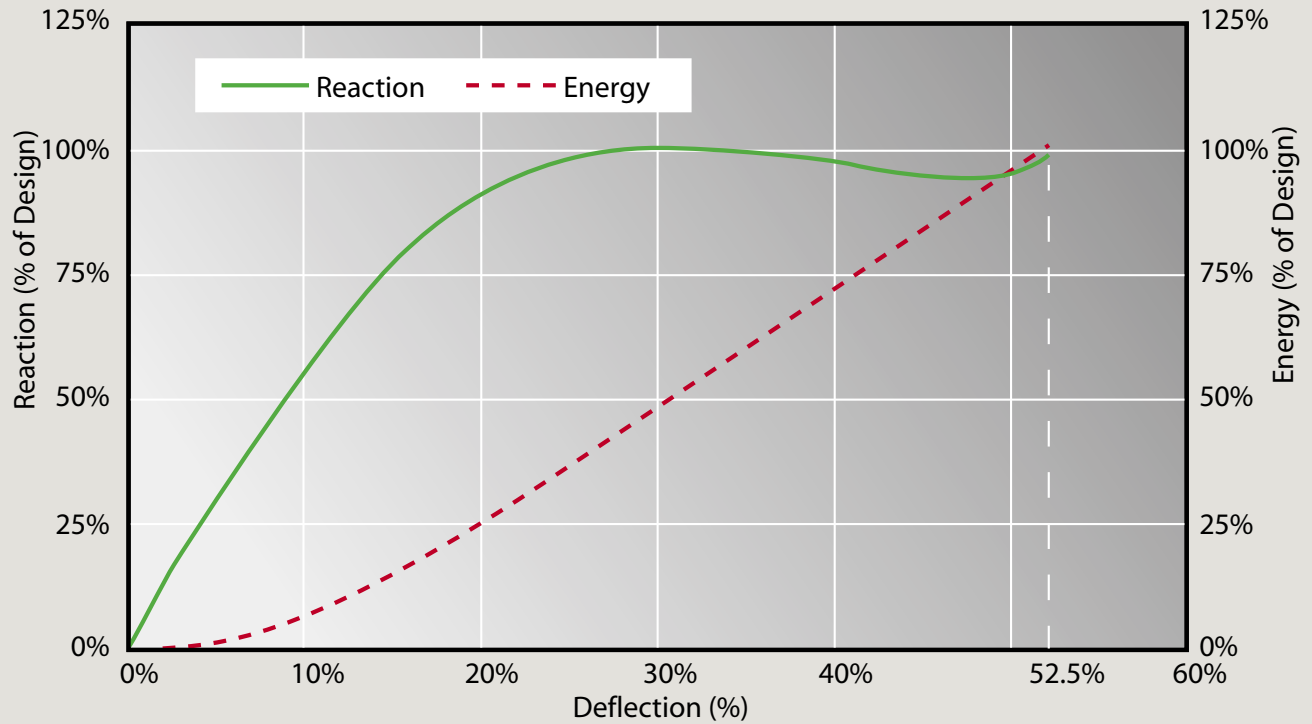

Intermediate grades can be interpolated from standard grades

AD PERFORMANCE

Model	Rubber Grade												Weight					
	G4				G3				G2						G1			
	R		E		R		E		R		E		R		E		kg/m	lb/m
kN	kips	kN-m	ft-kips	kN	kips	kN-m	ft-kips	kN	kips	kN-m	ft-kips	kN	kips	kN-m	ft-kips			
AD 250	265	59.6	27.8	20.5	203	45.6	21.4	15.8	169	38.0	17.7	13.0	145	32.6	15.2	11.2	87.5	193
AD 300	318	71.5	40.2	29.6	244	55.0	30.4	22.4	201	45.2	24.5	18.1	174	39.1	21.6	15.9	125	276
AD 400	423	95.1	71.5	52.7	325	73.1	54.9	40.5	270	60.7	45.1	33.2	231	52.0	39.2	28.9	205	452
AD 500	529	119	111	81.8	407	91.5	86.0	63.4	337	75.7	70.6	52.0	289	65.0	60.8	44.8	325	717
AD 600	634	143	160	118	488	110	124	91.4	404	91.0	102	75.2	347	78.0	87.0	64.1	480	1058
AD 800	847	190	284	209	651	146	219	161	539	121	181	133	463	104	156	115	875	1929
AD 1000	1058	238	445	328	813	183	342	252	675	152	283	209	578	130	243	179	1400	3087

R = reaction E = energy Values shown are for standard 52.5% deflection Maximum deflection = 55% R = 139% E = 107% Tolerance = +/- 10% Performance based on 1000mm length.

AD INTERMEDIATE RUBBER GRADES

Grade	Unit	AD 250		AD 300		AD 400		AD 500		AD 600		AD 800		AD 1000	
		kN kN-m	kips ft-kips	kN kN-m	kips ft-kips	kN kN-m	kips ft-kips	kN kN-m	kips ft-kips	kN kN-m	kips ft-kips	kN kN-m	kips ft-kips	kN kN-m	kips ft-kips
G1	R	145	32.6	174	39.1	231	51.9	289	65.0	347	78.0	463	104	578	130
	E	15.2	11.2	21.6	15.9	39.2	28.9	60.8	44.8	87.0	64.1	156	115	243	179
G1.1	R	147	33.1	177	39.7	235	52.8	294	66.1	353	79.3	471	106	588	132
	E	15.5	11.4	21.9	16.1	39.8	29.3	61.8	45.5	88.5	65.2	159	117	247	182
G1.2	R	150	33.7	179	40.3	239	53.7	299	67.1	358	80.6	478	108	597	134
	E	15.7	11.6	22.2	16.3	40.4	29.8	62.8	46.3	90.0	66.3	161	119	251	185
G1.3	R	152	34.2	182	40.9	243	54.6	303	68.2	364	81.9	486	109	607	136
	E	16.0	11.8	22.5	16.6	41.0	30.2	63.7	47.0	91.5	67.4	164	120	255	188
G1.4	R	155	34.8	185	41.5	247	55.4	308	69.3	370	83.1	493	111	617	139
	E	16.2	11.9	22.8	16.8	41.6	30.6	64.7	47.7	93.0	68.5	166	122	259	191
G1.5	R	157	35.3	188	42.2	251	56.3	313	70.4	376	84.4	501	113	627	141
	E	16.5	12.1	23.1	17.0	42.2	31.1	65.7	48.4	94.5	69.6	169	124	263	194
G1.6	R	159	35.8	190	42.8	254	57.2	318	71.4	381	85.7	509	114	636	143
	E	16.7	12.3	23.3	17.2	42.7	31.5	66.7	49.1	96.0	70.8	171	126	267	197
G1.7	R	162	36.4	193	43.4	258	58.1	323	72.5	387	87.0	516	116	646	145
	E	17.0	12.5	23.6	17.4	43.3	31.9	67.7	49.9	97.5	71.9	174	128	271	200
G1.8	R	164	36.9	196	44.0	262	58.9	327	73.6	393	88.3	524	118	656	147
	E	17.2	12.7	23.9	17.6	43.9	32.4	68.6	50.6	99.0	73.0	176	130	275	203
G1.9	R	167	37.5	198	44.6	266	59.8	332	74.7	398	89.5	531	119	665	150
	E	17.5	12.9	24.2	17.8	44.5	32.8	69.6	51.3	101	74.1	179	132	279	206
G2	R	169	38.0	201	45.2	270	60.7	337	75.8	404	90.8	539	121	675	152
	E	17.7	13.0	24.5	18.1	45.1	33.2	70.6	52.0	102	75.2	181	133	283	209
G2.1	R	172	38.8	205	46.2	276	61.9	344	77.3	412	92.7	550	124	689	155
	E	18.1	13.3	25.1	18.5	46.1	34.0	72.1	53.2	104	76.8	185	136	289	213
G2.2	R	176	39.5	210	47.1	281	63.2	351	78.9	421	94.6	561	126	703	158
	E	18.4	13.6	25.7	18.9	47.1	34.7	73.7	54.3	106	78.4	189	139	295	217
G2.3	R	179	40.3	214	48.1	287	64.4	358	80.5	429	96.5	573	129	716	161
	E	18.8	13.9	26.3	19.4	48.0	35.4	75.2	55.4	109	80.0	192	142	301	222
G2.4	R	183	41.1	218	49.1	292	65.6	365	82.1	438	98.4	584	131	730	164
	E	19.2	14.1	26.9	19.8	49.0	36.1	76.8	56.6	111	81.7	196	145	307	226
G2.5	R	186	41.8	223	50.0	298	66.9	372	83.6	446	100	595	134	744	167
	E	19.6	14.4	27.5	20.2	50.0	36.9	78.3	57.7	113	83.3	200	147	313	230
G2.6	R	189	42.6	227	51.0	303	68.1	379	85.2	454	102	606	136	758	170
	E	19.9	14.7	28.0	20.7	51.0	37.6	79.8	58.8	115	84.9	204	150	318	235
G2.7	R	193	43.3	231	52.0	309	69.4	386	86.8	463	104	617	139	772	173
	E	20.3	15.0	28.6	21.1	52.0	38.3	81.4	60.0	117	86.5	208	153	324	239
G2.8	R	196	44.1	235	52.9	314	70.6	393	88.4	471	106	629	141	785	177
	E	20.7	15.2	29.2	21.5	52.9	39.0	82.9	61.1	120	88.1	211	156	330	243
G2.9	R	200	44.9	240	53.9	320	71.8	400	89.9	480	108	640	144	799	180
	E	21.0	15.5	29.8	22.0	53.9	39.7	84.5	62.2	122	89.8	215	159	336	248
G3	R	203	45.6	244	54.9	325	73.1	407	91.5	488	110	651	146	813	183
	E	21.4	15.8	30.4	22.4	54.9	40.5	86.0	63.4	124	91.4	219	161	342	252
G3.1	R	209	47.0	251	56.5	340	76.5	419	94.2	503	113	671	151	838	188
	E	22.0	16.2	31.4	23.1	56.6	41.7	88.5	65.2	128	94.0	226	166	352	260
G3.2	R	215	48.4	259	58.2	356	79.9	431	97.0	517	116	690	155	862	194
	E	22.7	16.7	32.4	23.8	58.2	42.9	91.0	67.1	131	96.7	232	171	363	267
G3.3	R	222	49.8	266	59.8	371	83.4	444	99.7	532	120	710	160	887	199
	E	23.3	17.2	33.3	24.6	59.9	44.1	93.5	68.9	135	99.3	239	176	373	275
G3.4	R	228	51.2	274	61.5	386	86.8	456	102	546	123	729	164	911	205
	E	24.0	17.7	34.3	25.3	61.5	45.4	96.0	70.8	138	102	245	181	383	282
G3.5	R	234	52.6	281	63.2	402	90.3	468	105	561	126	749	168	936	210
	E	24.6	18.1	35.3	26.0	63.2	46.6	98.5	72.6	142	105	252	185	394	290
G3.6	R	240	54.0	288	64.8	417	93.7	480	108	576	129	769	173	960	216
	E	25.2	18.6	36.3	26.7	64.9	47.8	101	74.4	146	107	258	190	404	298
G3.7	R	246	55.4	296	66.5	432	97.1	492	111	590	133	788	177	985	221
	E	25.9	19.1	37.3	27.5	66.5	49.0	104	76.3	149	110	265	195	414	305
G3.8	R	253	56.8	303	68.2	447	101	505	113	605	136	808	182	1009	227
	E	26.5	19.5	38.2	28.2	68.2	50.2	106	78.1	153	113	271	200	424	313
G3.9	R	259	58.2	311	69.8	463	104	517	116	619	139	827	186	1034	232
	E	27.2	20.0	39.2	28.9	69.8	51.5	109	80.0	156	115	278	205	435	320
G4	R	265	59.6	318	71.5	478	107	529	119	634	143	847	190	1058	238
	E	27.8	20.5	40.2	29.6	71.5	52.7	111	81.8	160	118	284	209	445	328

R = reaction E = energy Values shown are for standard 52.5% deflection Maximum deflection = 55% R = 139% E = 107% Tolerance = +/- 10%
Performance based on 1000mm length.